

Operating Instructions and Parts Manual Model "J4"

Please read and save these instructions. Read carefully before attempting to assemble, install, operate or maintain the product described. Protect yourself and others by observing all safety information. Failure to comply with instructions could result in personal injury and/or property damage. Retain instructions for future reference.

WORLD DRYER AIRFORCE™ High Efficiency Hand Dryer

Description

World warm air hand dryer, powered by universal brush motor, delivers 1100 Watts of drying power. This hand dryer runs on 230 Volts AC electrical supply. An infrared sensor is used to automatically turn the dryer on and off. This model is intended for use in commercial, industrial, office and public facility environments.

General Specifications

Model	Drying Cycle	Dimensions (W x H x D)	Weight
J4-162 Black	Auto	8.9" x 10.6" x 6.4"	7.1 lbs
J4-974 White	Auto	(22.6cm x 27cm x 16.2cm)	(3.2 Kg)
J4-970 Chrome	Auto		

Electrical Specifications

UL LISTED E320188

Model	Type	Electrical Input	Amperage	Watts
J4	Automatic	230VAC-50/60Hz	4.8A	1100

Unpacking

1. Remove all packing material.
Recycling is recommended.
2. Carefully remove the hand dryer from the shipping carton, using care not to drop the appliance.
3. Inspect carefully for any damage that may have occurred during transit. Check for any loose, missing or damaged parts. If the hand dryer is damaged, promptly inform the dealer where you purchased it.



Printed in China



WORLD DRYER AIRFORCE™

High Efficiency Hand Dryer

General Safety Information

⚠ DANGER *Failure to disconnect the power source before installation can result in serious injury or death from electric shock.*

- Always disconnect the power source before servicing or installing the hand dryer.

⚠ DANGER *Failure to properly ground this unit could result in severe electrical shock and/or death*

- This hand dryer must be properly grounded (Earthed) for safe operation. An identified ground connection point is supplied on the chassis of the hand dryer.
- We recommend GFCI protection in wet or damp locations or as required by local code.

⚠ WARNING *Risk of fire, personal injury or property damage are possible if local codes, or safety recommendations are not followed.*

- Use only the electrical power (voltage and frequency) specified for the model hand dryer being installed.
- Connect the hand dryer to the nearest suitable distribution panel.
- To limit a voltage drop, and insure efficient operation, use No. 12 wire or larger as required by local or National Electrical Code.
- Do not connect to a branch circuit with circuit breaker or fuse protection over 15 Amps.
- All automatic model hand dryers must have dedicated circuit.
- Route all field wiring away from moving parts within the hand dryer.

⚠ CAUTION *Improper mounting could result in personal injury or property damage.*

- Follow the mounting recommendations in Table 1.
- On a stud wall, one side of the hand dryer should be mounted to an existing stud.

Installation

1. Disconnect the power source.
2. Use the security hex key supplied to turn the cover mounting screws clockwise to remove the cover from the dryer.
3. Place the hand dryer base on the wall at the desired location using Table 1 to determine the recommended mounting height. With the base so located, use it as a template to mark locations of the 4 mounting bolt holes on the wall. Ensure that no reflective object (such as a hand basin) is located directly under infra-red sensor eye; the minimum distance is 18 inches (46 cm).
4. Fasten the base to the wall, using the type of bolts suggested in Table 2.
5. All automatic dryers must have their own dedicated 15 amp circuit.
6. Connect the dryer to the nearest suitable distribution panel.
7. Replace cover, turn screws counter-clockwise making certain not to over-tighten.

IMPORTANT: Consult local and general regulations before performing dryer installation. Ensure that the electrical network is not overloaded. Do not connect to a branch circuit over 15 amps.

WORLD DRYER AIRFORCE™
High Efficiency Hand Dryer

Maintenance

1. Remove fuse or shut off power to the dryer at fuse box.
2. With Allen wrench supplied with dryer, turn clockwise two Allen screws from bottom side of dryer case.
3. Remove dryer cover.

CLEANING INSTRUCTIONS

Read complete instruction before proceeding. Under normal use, cleaning the Dryer once a year will keep it in good operating condition. If the washroom traffic is heavier than normal, the cleaning should be done every 6 months. Lint and dust build up inside the dryer can result in damage to motor.

1. Turn off dryer at circuit breaker or fuse panel.
2. Turn clockwise two cover mounting screws from dryer cover using security hex key provided. Support cover while removing screws.
3. Vacuum out dirt from blower and housing. Use caution not to damage wires or circuit boards.
4. The motor inlet cover may be removed by unscrewing the (4) screws. This allows access to the motor for cleaning or replacement.
5. Use soft-medium bristle ½” paint brush to clean dust and dirt from motor.
6. Replace cover. Place cover squarely over base and push flush to wall. Turn cover mounting screws counter-clockwise and tighten until snug. Do not over tighten.

Table 1

Recommended Mounting Heights from Floor to Dryer Bottom Edge	
	in. (cm.)
Men’s washrooms	46 (117)
Women’s washrooms	44 (112)
Children’s washrooms, ages 4-7	32 (81)
Children’s washrooms, ages 7-10	36 (91)
Children’s washrooms, ages 10-13	40 (102)
Children’s washrooms, ages 13-17	44 (112)
Handicap Mounting Height	37 (94)

Table 2

Type of Wall	Type of Bolt	Minimum Bolt Length
Hollow Tile, Lath, Wall Board or Metal	¼” (M6) screw Type or Wing Type toggle Bolts	Dependent on wall thickness
Cement, Brick, or Tile Covered Cement or Brick	¼” (M6) Stud Type Expansion Bolts	3” (76mm)
Stud Wall with wood Backing	No 16 (M8) Wood Screws	2-3/4” (70mm)



WORLD DRYER AIRFORCE™
High Efficiency Hand Dryer

REPAIR PARTS LIST FOR AIRFORCE™ HAND DRYER

Reference Number	Description	Part Number	Qty
1	Base	14-011577	1
2	Motor Housing	47-011573	1
3	Earth Clip	52-030244	1
4	Cable Clamp	12-011578	1
5*	Screw-No6 x 1/2 - Poz Pan	46-040121	4
6*	Screw-No8 x 3/8 - Poz Pan	46-040049	4
7*	Screw-No6 x 3/8 - Poz Pan	46-010008	3
8	Screw M5x16 Plas Tech 30 Flange HD	46-333	4
9	Seal	59-011574-1	1
10	Outlet Lens	30-011576	1
11	Motor	32-12214300	1
12	Screw M4x10 Taptite Poz Pan	46-040194	2
13	Motor Cover with Muffler Felt	20-200901	1
14	Cover Bracket	33-011579	2
15	Cover	20-030243	1
16	World Sensor PCB	49-200	1
17	Cover Screw Cap	59-011587	2
18	M6x25 Sac HD Cap Screw	46-040221	2
19	Bracket, Power Circuit Board	33-200	1
20	World Motherboard	16-200	1
21*	Screw-No4-3/8 P/Plan Plasfix 60	46-040229	4
22	Brass Nut M5	35-007J	2
23*	Installation Kit (Screw w/Washer #8 and Anchor)	46-90398K	4
24	Fishpaper J/ J4 PCB Insulator	12-8490	1
25	Mounting Isolation Kit (Spacer + 2 Grummets)	59-005517K	4
26	Fixing Kit "5 mm Allen wrench"	56-40189	1
27	Gasket, Motor Chamber	27-200903	1
28*	Screw #6x3/8 SS Truss Phillips	099-058	2
29	Ground Screw	46-002J	1

(* Standard Hardware Store Fasteners.



WORLD DRYER AIRFORCE™
High Efficiency Hand Dryer

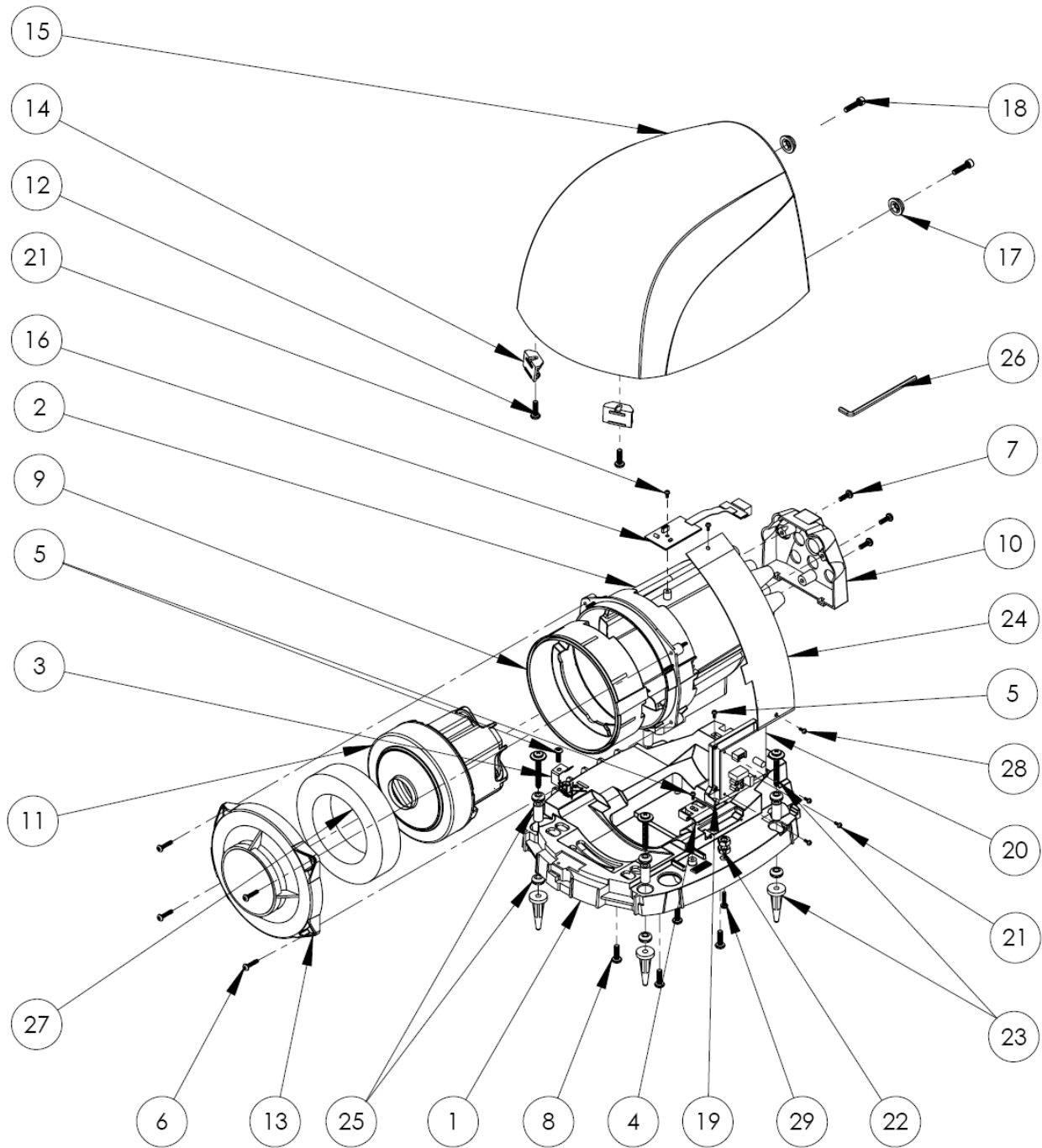

For Repair Parts, call in the US 1.800.323.0701

Please provide following information:

- Model number
- Serial number
- Part description and number shown in parts list

WORLD DRYER AIRFORCE™
 High Efficiency Hand Dryer
 Troubleshooting Chart

Symptom	Possible Cause(s)	Corrective Action
Dryer fails to start.	A) No power to unit. B) Defective motor.	Check power to unit and connections. Replace motor.
Dryer will not shut off or runs 20 seconds, then will not re-start.	Sensor is dirty, defective or there is a reflection.	1. Check infra-red eye for dirt or damage. Use plastic lenses cleaning solution and a soft cloth. Dry lens with a soft cloth. 2. Make sure that sensor is not getting a reflection from another object. 3. After electricity has been applied to the dryer, it should turn on within few seconds. Test by placing hands 3 to 6 inches below the nozzle. 4. Replace circuit boards.

LIMITED WARRANTY

World LIMITED THREE – YEAR WARRANTY. World Warm Air Hair Dryer, Model covered in this manual, is warranted by **World Dryer Corporation** to the original user against defects in workmanship or materials under normal use for 3 years after date of purchase. Any part which is determined to be defective in material or workmanship and returned to an authorized service location, as **World** designates, shipping costs prepaid, will be, as the exclusive remedy, repaired or replaced at **World’s** option. For limited warranty claim procedures, see PROMPT DISPOSITION below. This limited warranty gives purchasers specific rights from jurisdiction to jurisdiction.

LIMITATION OF LIABILITY. To the extent allowable under applicable law, **World’s** liability for consequential and incidental damages is expressly disclaimed. **World’s** liability in all events is limited to and shall not exceed the purchase price paid.

WARRANTY DISCLAIMER. World has made a diligent effort to provide product information and illustrate the products in this literature accurately; however, such information and illustrations are for the sole purpose of identification, and do not express or imply a warranty that the products are MERCHANTABLE, or FIT FOR A PARTICULAR PURPOSE, or that the products will necessary conform to the illustrations or descriptions. Except as provided below, no warranty or affirmation on fact, expressed or implied, other than as stated in the “LIMITED WARRANTY” above is made or authorized by **World**.

PRODUCT SUITABILITY. Many jurisdictions have codes and regulations governing sales, construction, installation, and/or use of products for certain purposes, which may vary from those in neighboring areas. While **World** attempts to assure that the products comply with such codes, it cannot guarantee compliance, and cannot be responsible for how the product is installed or used. Before purchase and use of a product, review the product application, and all applicable national and local codes and regulations, and be sure that the product, installation, and use will comply with them.

Certain aspects of disclaimers are not applicable to consumer products; e.g., (a) some jurisdictions do not allow the exclusion or limitation of incidental or consequential damages, so the above limitation or exclusion may not apply to you; (b) also, some jurisdictions do not allow a limitation on how long an implied warranty lasts, consequentially the above limitation may not apply to you; and (c) by law, during the period of this Limited Warranty, and implied warranties of implied merchantability or fitness for particular purpose applicable to consumer products purchased by consumers, may not be excluded or otherwise disclaimed.

PROMPT DISPOSITION. World will make a good faith effort for prompt correction or other adjustment with respect to any product which proves to be defective within limited warranty. For any product believed to be defective within limited warranty, first write or call dealer from whom the product was purchased. Dealer will give additional directions. If unable to resolve satisfactorily, write to **World** at address below, giving dealer’s name, address, date, and number of dealer’s invoice, and describing the nature of defect. Title and risk of loss pass to buyer on delivery to common carrier. If product was damaged in transit to you, file claim with carrier.

Manufactured by World Dryer Corporation Berkeley, Illinois 60163 U.S.A.

